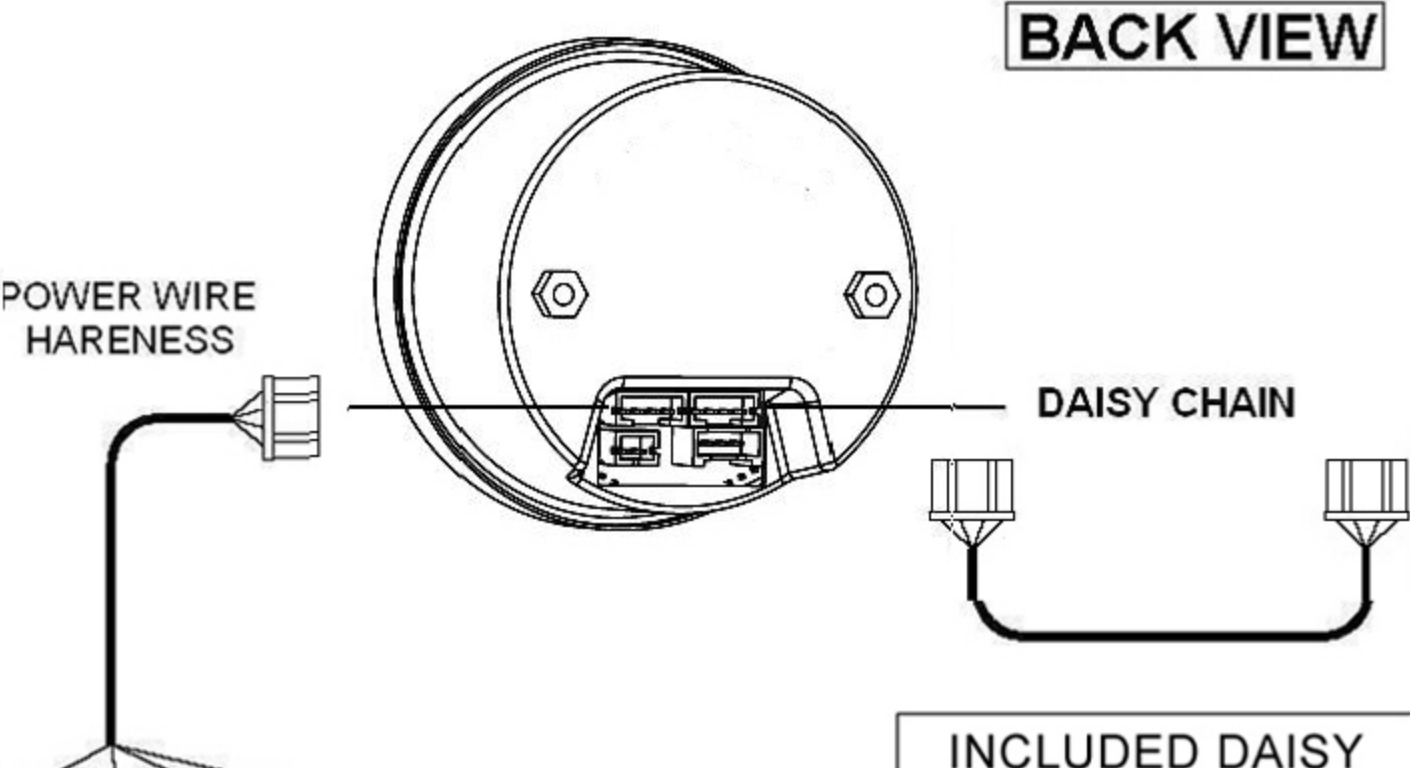
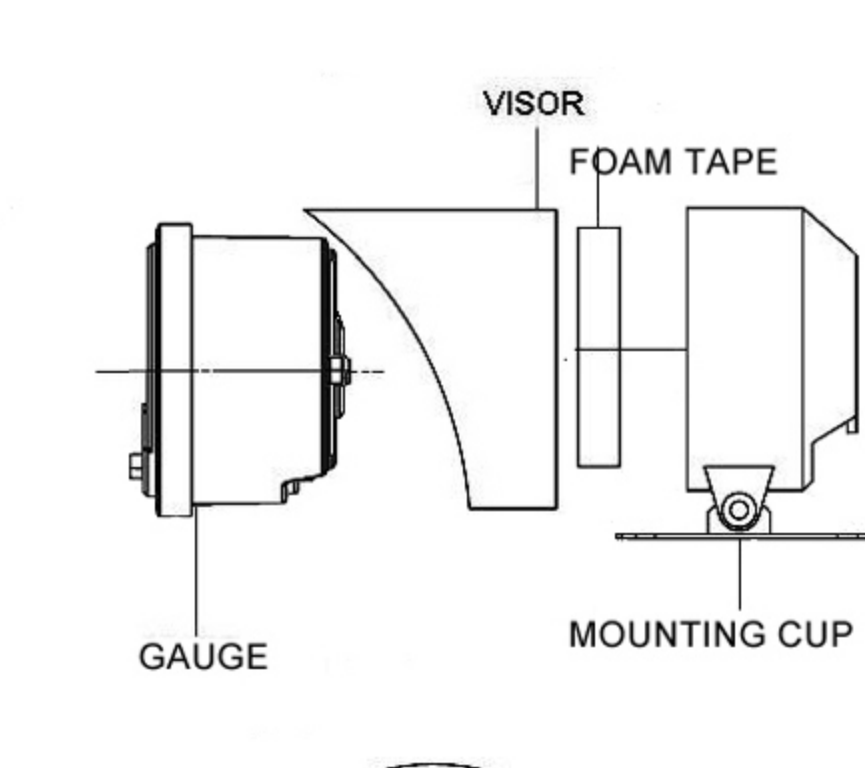
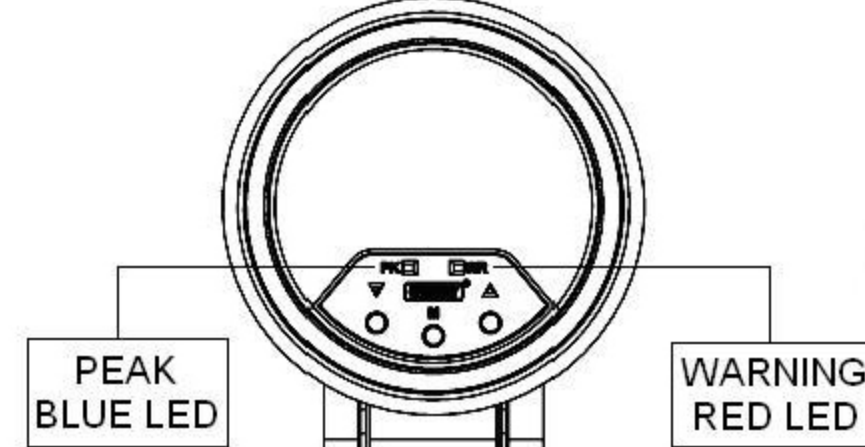
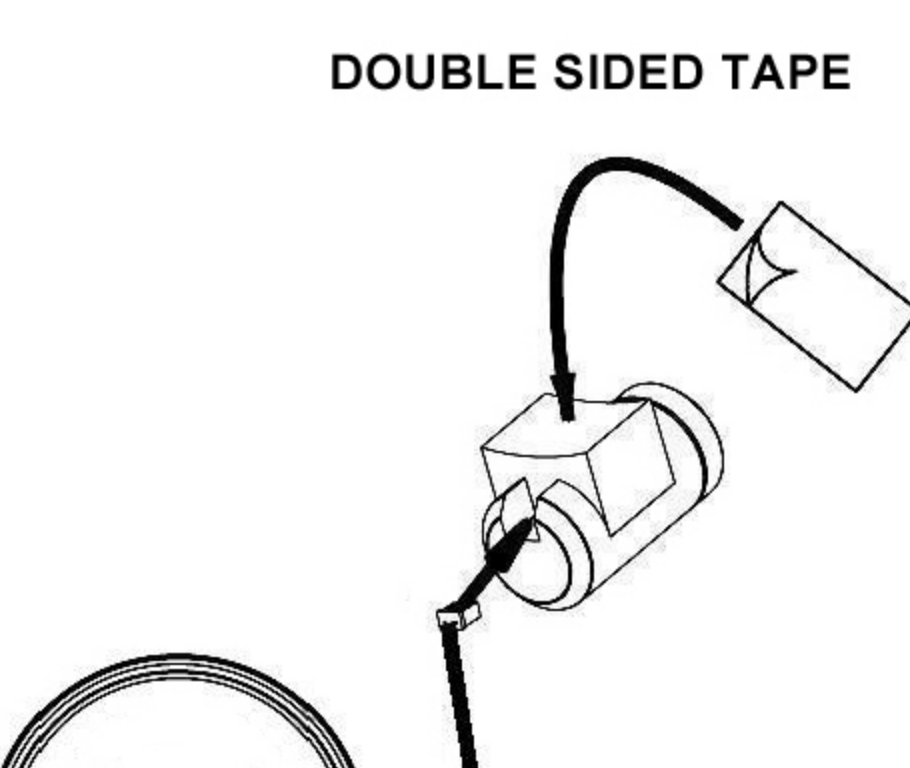
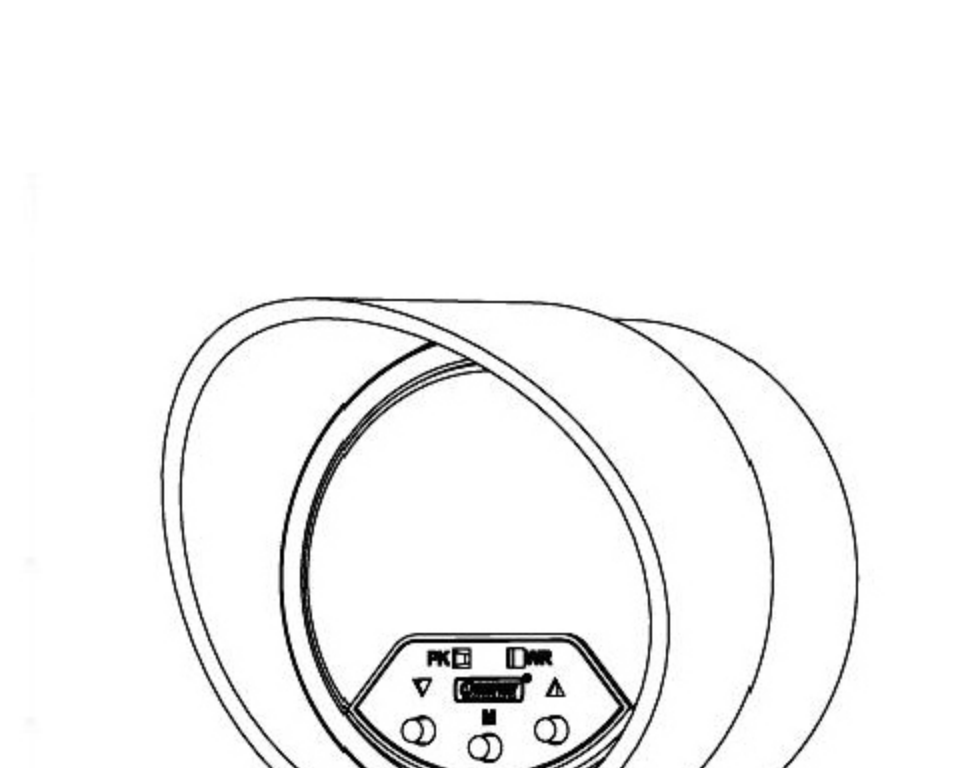

# INSTALLATION INSTRUCTIONS

## 60MM PREMIUM EVO SERIES W/ WARNING & PEAK

WHITE / RED / GREEN / BLUE LED DISPLAY

### Volt Gauge

<p style="text-align: center;"><b>BACK VIEW</b></p>  <p style="text-align: center;">DAISY CHAIN</p> <p style="text-align: center;">INCLUDED DAISY CHAIN USED TO POWER ADDITIONAL GAUGES</p> <p>RED - Constant 12v BLACK - Ground WHITE - Accessory 12v ORANGE - 12v Headlight switch (For dimming at night)</p>	 <p style="text-align: center;">VISOR FOAM TAPE MOUNTING CUP</p> <p style="text-align: center;">GAUGE</p>  <p style="text-align: center;">PEAK BLUE LED      WARNING RED LED</p>	<p style="text-align: center;">DOUBLE SIDED TAPE</p>  <p style="text-align: center;">OPTIONAL EXTERNAL WARNING LIGHT SOLD SEPARATELY</p>	 <p style="text-align: center;"><b>Complete Set</b></p>
---	--	---	--

### Boost / Vacuum Gauge

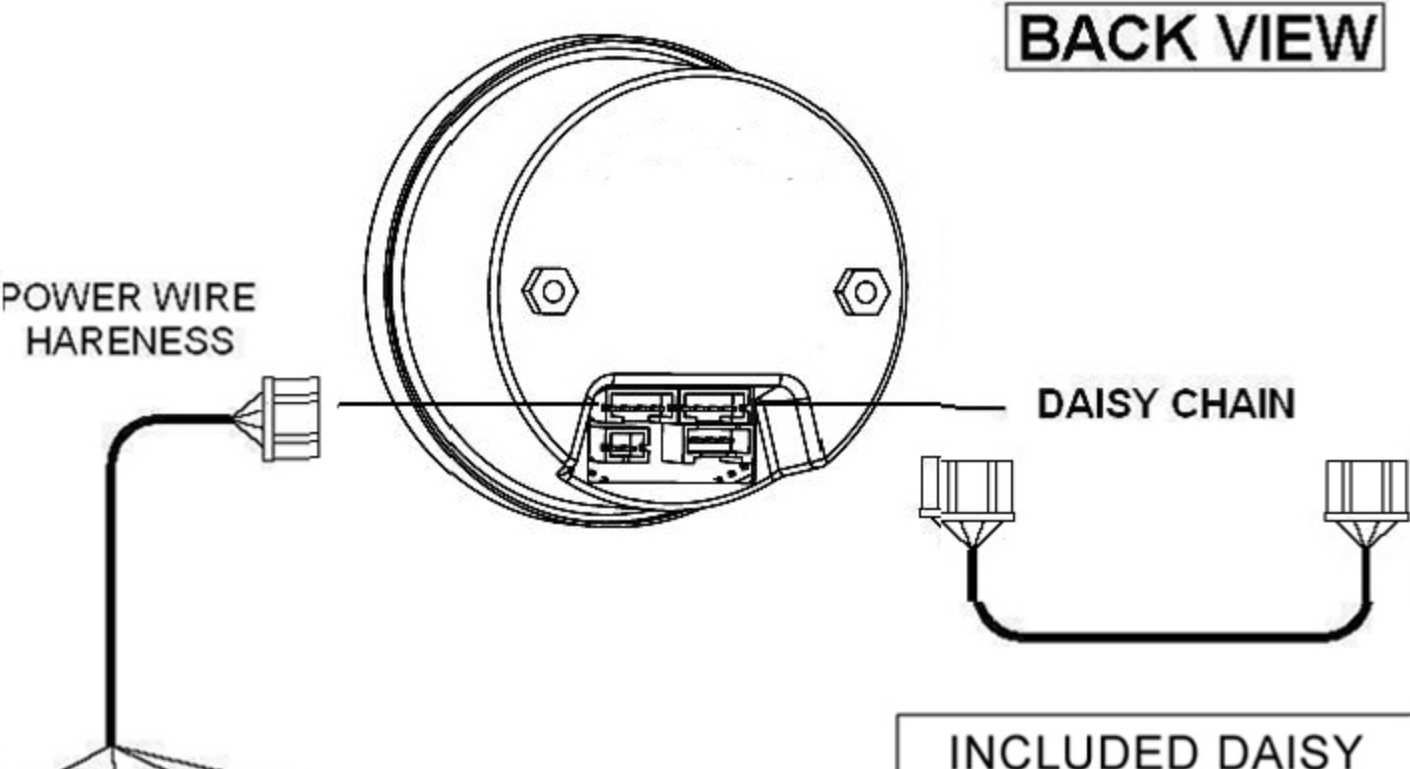
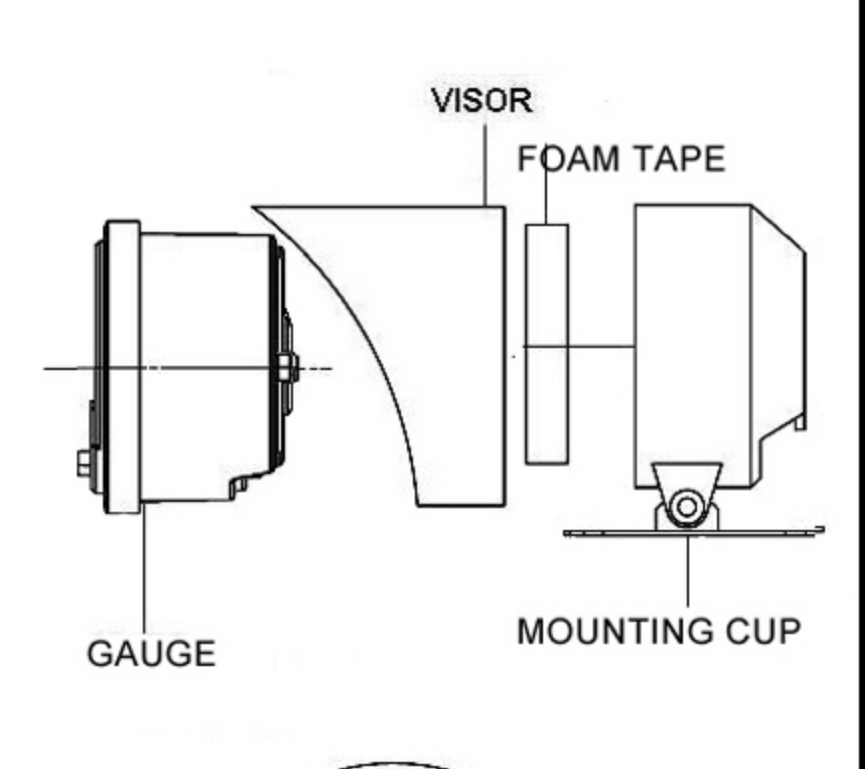
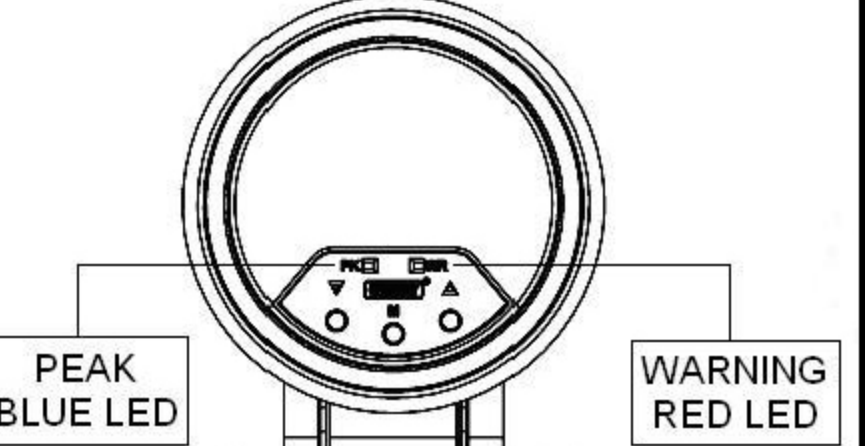
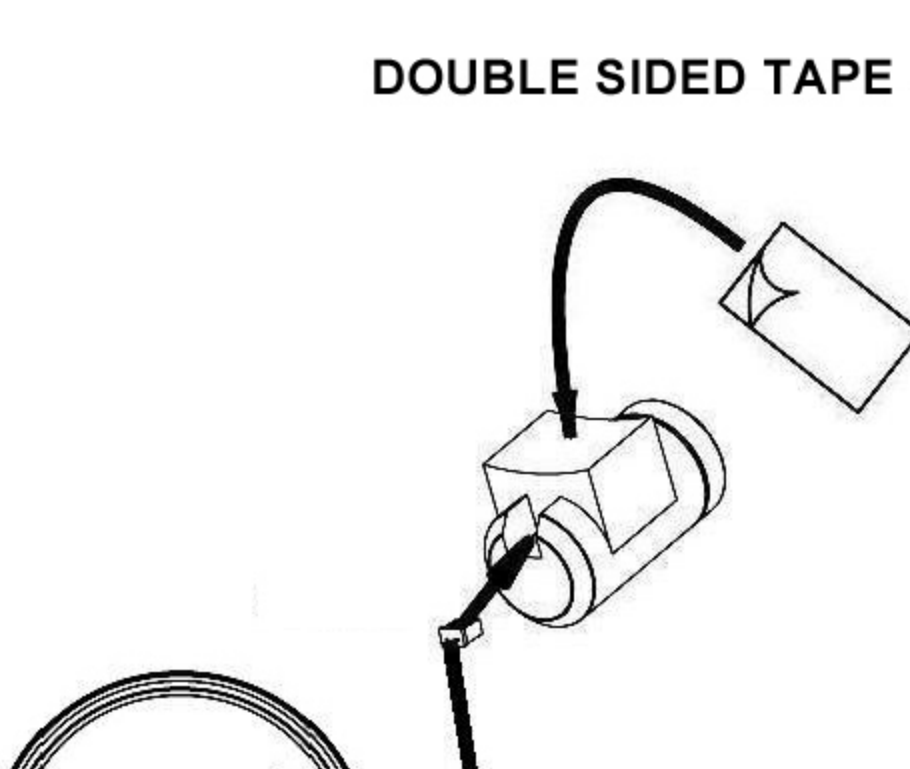
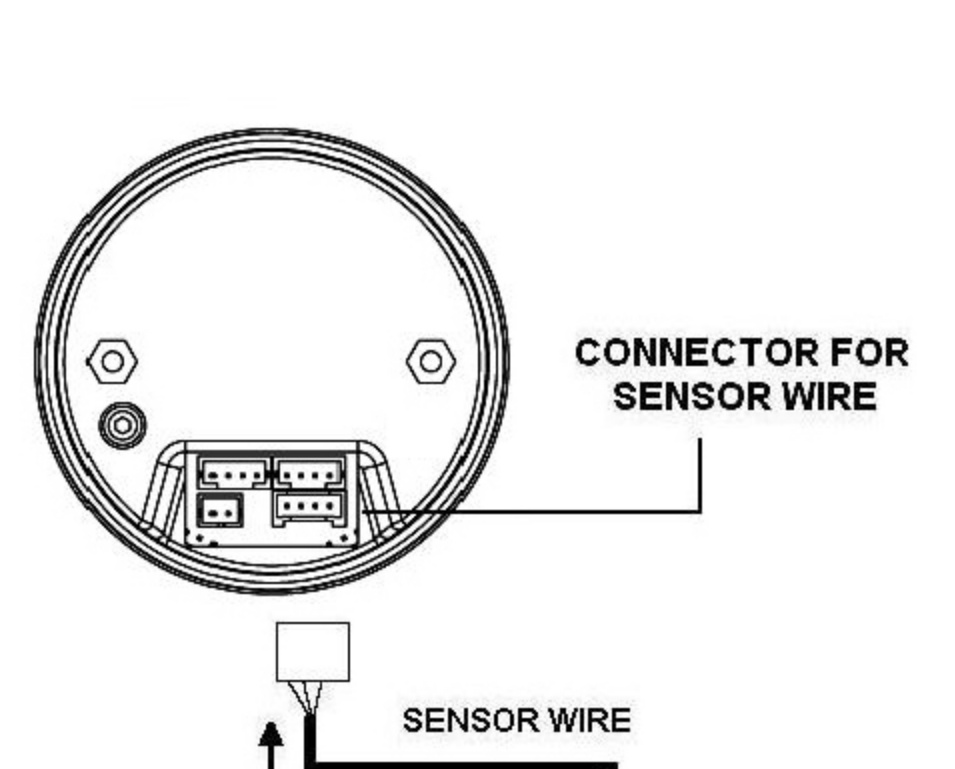
<p style="text-align: center;"><b>BACK VIEW</b></p>  <p style="text-align: center;">DAISY CHAIN</p> <p style="text-align: center;">INCLUDED DAISY CHAIN USED TO POWER ADDITIONAL GAUGES</p> <p>RED - Constant 12v BLACK - Ground WHITE - Accessory 12v ORANGE - 12v Headlight switch (For dimming at night)</p>	 <p style="text-align: center;">VISOR FOAM TAPE MOUNTING CUP</p> <p style="text-align: center;">GAUGE</p>  <p style="text-align: center;">PEAK BLUE LED      WARNING RED LED</p>	<p style="text-align: center;">DOUBLE SIDED TAPE</p>  <p style="text-align: center;">OPTIONAL EXTERNAL WARNING LIGHT SOLD SEPARATELY</p>	 <p style="text-align: center;">CONNECTOR FOR SENSOR WIRE</p> <p style="text-align: center;">SENSOR WIRE</p> <p style="text-align: center;">WHITE CONNECTOR</p> <p style="text-align: center;">BLACK      RED      WHITE</p> <p style="text-align: center;"><b>BACK VIEW</b>      VACUUM / BOOST SENSOR</p>
---	--	---	--

### BOOST INSTALLATION

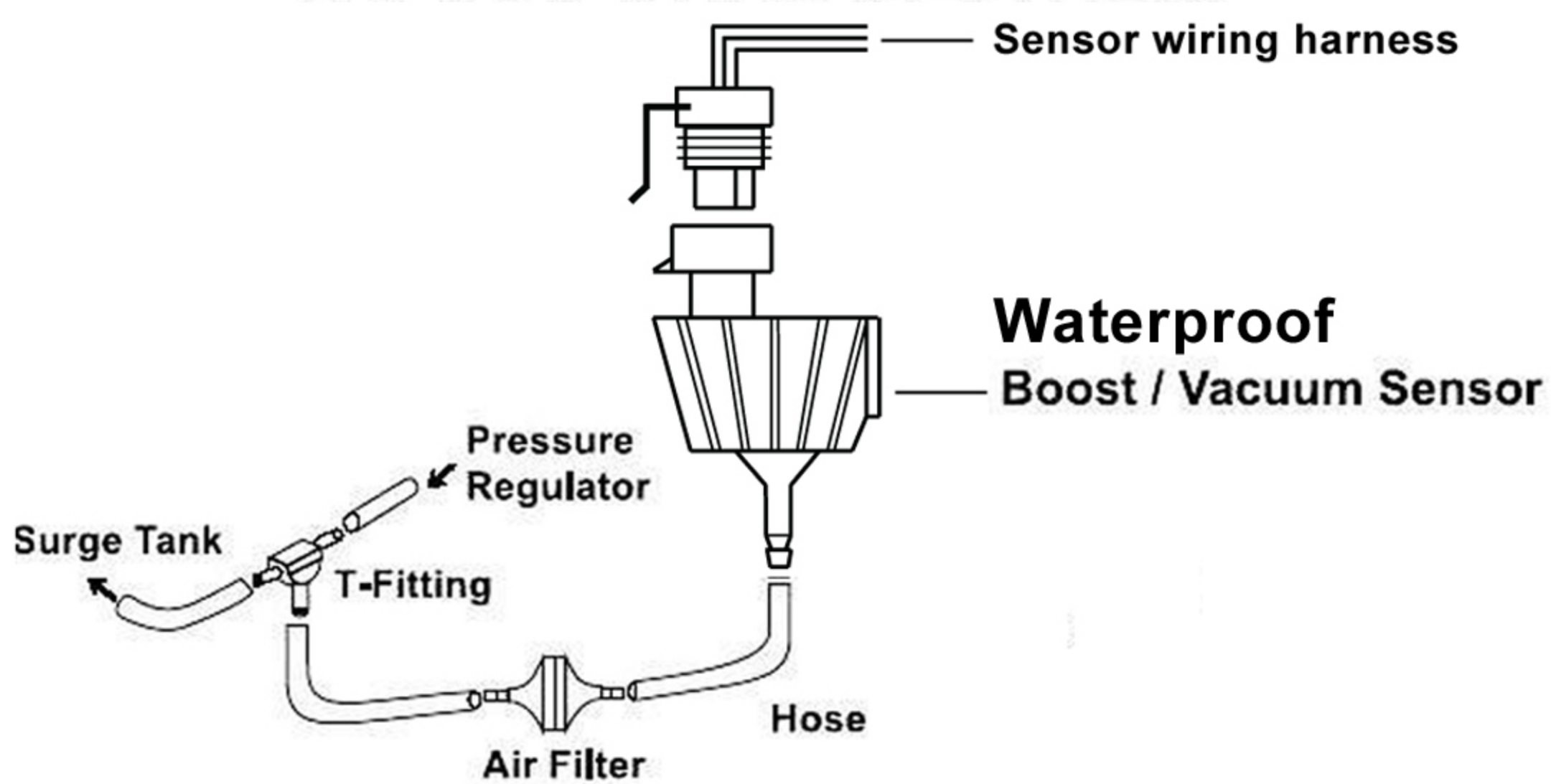

#### Is your gauge not sitting at zero?

To compensate for altitude you can zero out the gauge using the supplied key (or 2mm allen wrench).

With the key on - engine off, wait for the gauge to stop moving and slowly turn the screw until the gauge reads zero.

